

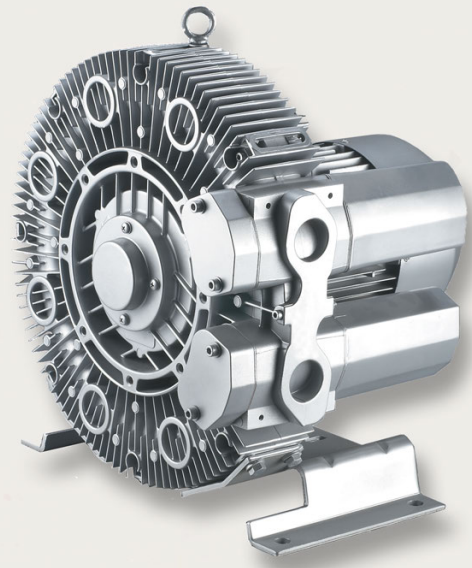

Side channel blower 314 series

The standard VACOM® design, with housing an impeller made of aluminum alloy, is a direct drive configuration, with a dynamically balanced impeller, fitted directly on the motor shaft. The impeller rotates inside of the stator housing with a very small clearance. The absence of lubricants guarantees a 100% oil free vacuum or compression. Construction features of the VACOM® side channel blower are the very reliable operation and low maintenance. VACOM® blowers are directly driven, impellers fixed directly on the drive shaft. Impeller bearing is installed in the front cover and easily to assemble and disassemble. Machines are small and lightweight. VACOM® blowers are already available with differential pressures up to 700 mbar and capacities of 2000 m³/ hr.



Features

- ◆ Available from stock
- ◆ Almost free of maintenance
- ◆ Low power consumption
- ◆ Oil free compression, no oil in the medium
- ◆ Made of aluminum, so low weight and high corrosion resistance.

Accessories

- ◆ Suction filter TGF (for vacuum)
- ◆ Suction filter VCFT (for compression)
- ◆ Pressure relief valve DB
- ◆ External silencer EGD
- ◆ Fittings
- ◆ Various: change valve, pressure gauge, non return valve



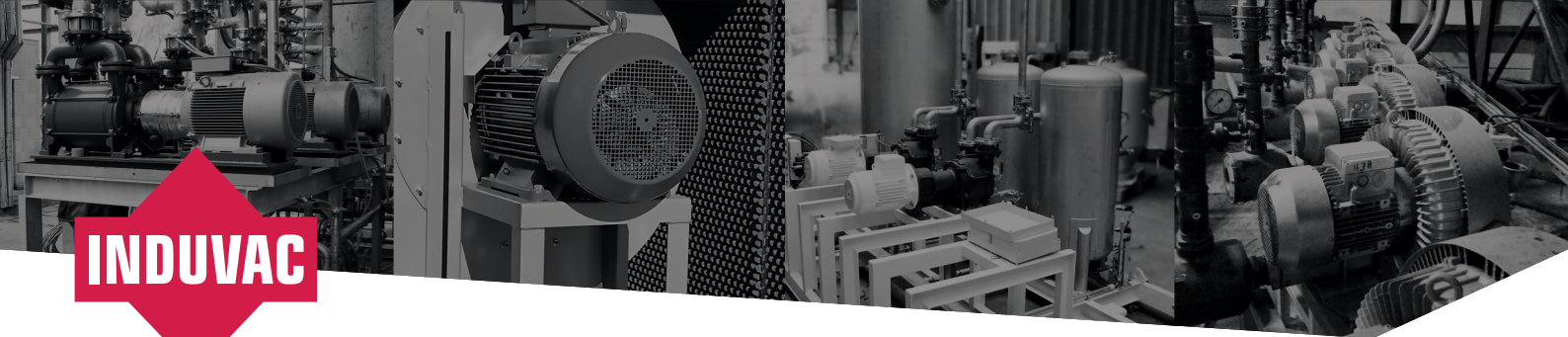

Technical data

Type No.	Curve No.	Freq. Hz	Power kW	Voltage V		Current A		Capaciteit m ³ /hr	Pressure difference mbar		Sound level dB(A)	Connection "G	Weight kg
				Δ	Y	Δ	Y		Vacuum	Pressure			
VC 305-314	314A	50	0,55	200-240 Δ	345-415 Y	2,80 Δ	1,60 Y	66	-250	250	57	1,25	16
	314B	60	0,63	220-275 Δ	380-480 Y	3,00 Δ	1,70 Y	80	-260	250	62	1,25	16
VC 308-314	314C	50	0,81	200-240 Δ	345-415 Y	4,00 Δ	2,30 Y	66	-280	350	57	1,25	17
	314D	60	0,94	220-275 Δ	380-415 Y	4,00 Δ	2,30 Y	80	-340	360	62	1,25	17

Curves

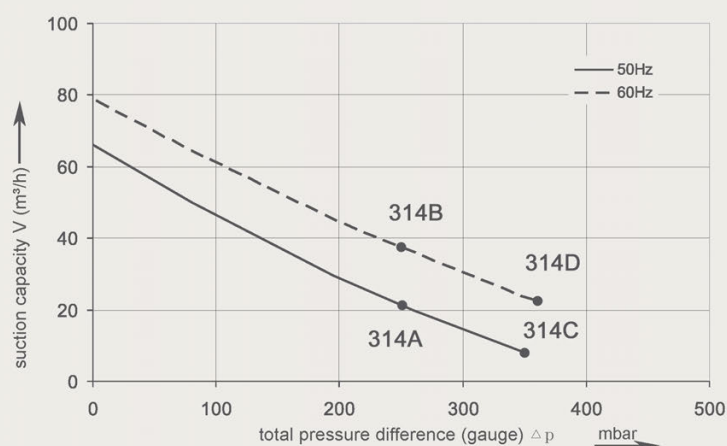
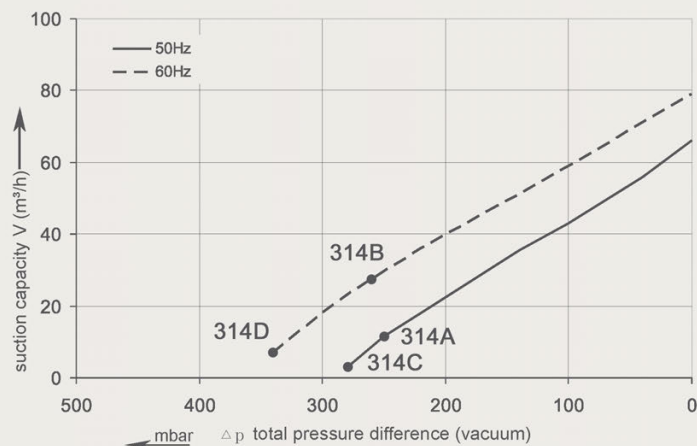

Curves are valid for dry air, with a temperature of 15°C at the inlet and a pressure of 1013 m bar(a) at the inlet or outlet connection (for over- or under-pressure application respectively). The tolerance on capacity is +/- 10%. No rights can be derived from the sketches, dimensions and contents of this data sheet. The data is for information purposes only. Induvac reserves the right to change or modify the data. No complaints can be made about this.

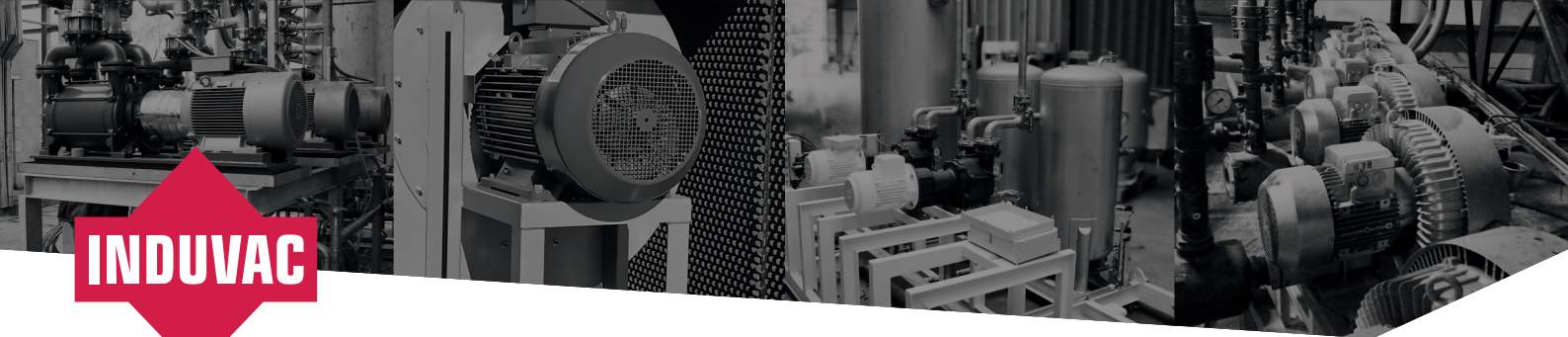

Dimensions

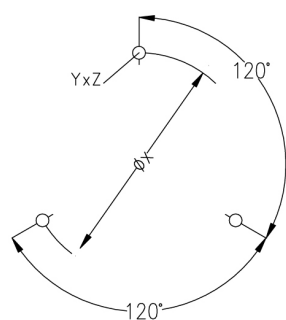
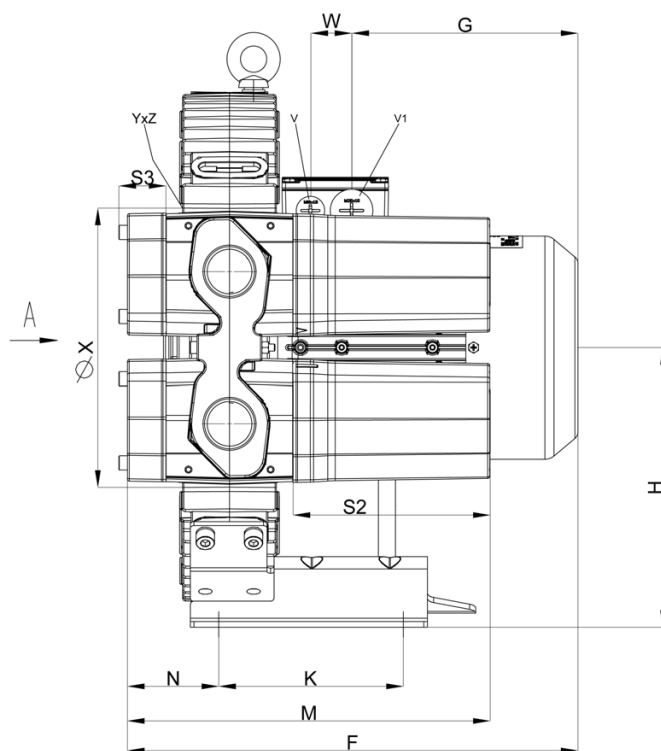
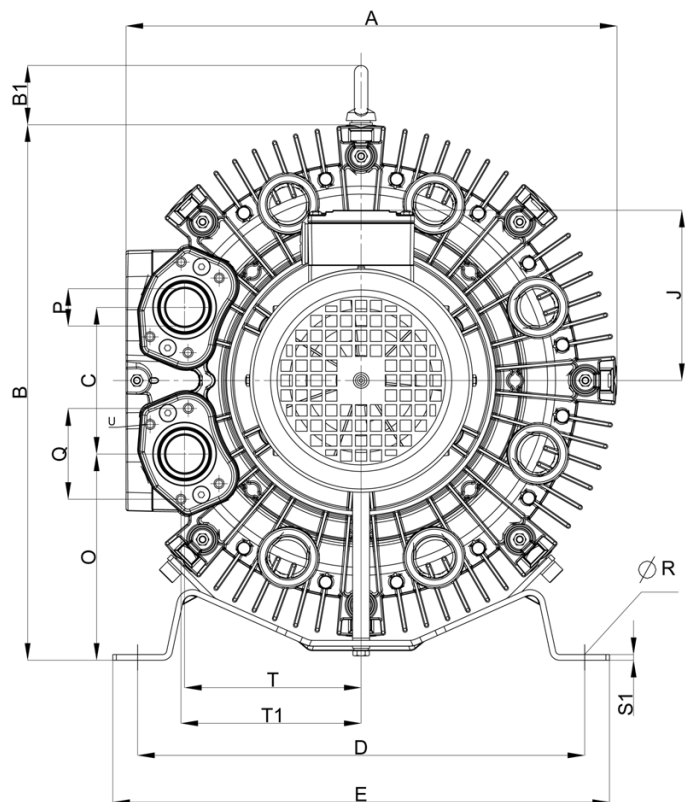

Curve No.	Type	A	B	B1	C	D	E	F	G	H	J	K	M	N
314 A/B	VC 305-314	313	339	39	94	290	325	295	153	177	120	105	256	67
314 C/D	VC 308-314	313	339	39	94	290	325	295	153	177	120	105	256	67
Curve No.	Type	O	P	Q	ØR	S	T	U	V	V1	XyZ	ØX	W	
314 A/B	VC 305-314	130	G1 1/4"	64	14	4	114	M6 x 17	M25 x 1,5	M16 x 1,5	M6 x 15	153	32	
314 C/D	VC 308-314	130	G1 1/4"	64	14	4	114	M6 x 17	M25 x 1,5	M16 x 1,5	M6 x 15	153	32	